

<b>Project:</b>	
<b>Type:</b>	
<b>Catalog #:</b>	

## STANDARD



## OPTIONAL



## ILLUMINATION

- Ultra bright, energy efficient, long life Red or Green LEDs.

## ELECTRICAL

- Dual 120/277 voltage.
- UniTue bi-color LED indicator light alerts occupant on battery condition (Green-normal, Red-check-battery).
- Charge rate/power "ON" LED indicator light and magnetic test switch for mandated code compliance testing.
- 4.8V long-life, maintenance-free, rechargeable NiCd battery (EM models only).
- Internal solid-state transfer switch automatically connects the internal battery to LED board for minimum 90-minute emergency illumination.
- Fully automatic solid-state, two-rate charger initiates battery charging to recharge a discharged battery in 24 hours.

## MOUNTING

- Universal knockout pattern on back provided with gasket for watertight seal for back mount.
- Polycarbonate mounting canopy included for top or end mount

## HOUSING

- Housing is reinforced polycarbonate construction in white or black finish.
- Corrosion-resistant enclosure with one piece, high-impact resistant, UV stabilized polycarbonate lens and molded gasket with stainless steel screws.
- Knockouts provided for conduit feed applications.
- EZ snap-out Chevron directional indicators.

## OPTIONS

- SDT: Self-diagnostic feature performs monthly, biannual, and annual tests to ensure reliable operation and meet electrical and life safety codes.
- 2C-120V/2C-277V: Voltage-specific dual circuit option on the AC-only unit enables it to be connected to two different supplies at the same time.
- TP: Tamper-proof hardware helps discourage unauthorized access to the unit.

## WARRANTY / LISTING

- Five year warranty on all electronics and housing. Batteries prorated for five years.
- Meets UL924, NFPA101 Life Safety Code, NEC, OSHA, Local and State Codes.
- IP66 rated for Ingress protection.
- NEMA4X and NSF rated.
- Certified to CEC under Title 20 Regulations.
- UL certified for use in food service operations.
- UL listed for wet locations (-20°C - 50°C).

## DIMENSIONS

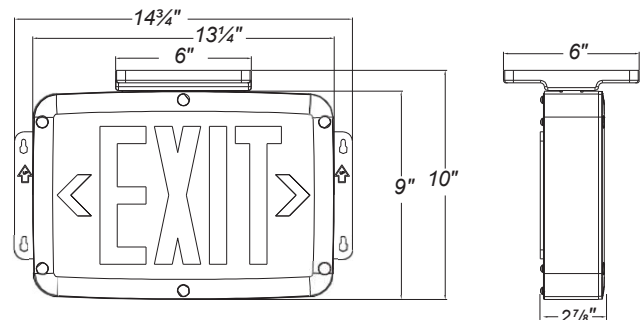

## ORDERING INFORMATION

Sample Part Number: **INDWLEZU1RBEMSDT**

MODEL	No. of FACES	LETTER COLOR	HOUSING COLOR	BATTERY	OPTIONS
INDWLEZU	1	Single	R Red	W White	(blank) AC-Only
	2	Double	G Green	B Black	EM NiCd Battery
					SDT Self-Diagnostics <sup>1</sup>
					2C-120 Dual Circuit With 120V Input <sup>2</sup>
					2C-277 Dual Circuit With 277V Input <sup>2</sup>
					TP Tamper-Proof

<sup>1</sup> Available in EM units only.  
<sup>2</sup> Not available with EM units.

<b>Project:</b>	
<b>Type:</b>	
<b>Catalog #:</b>	

## ELECTRICAL INFORMATION

CATALOG NUMBER	INPUT WATTS (W)	INPUT AMPS (A)	
		120V	277V
INDWLEZU (GREEN)	2.5	0.025	0.010
INDWLEZU (RED)	2.5	0.025	0.010